

PROCESS HEAT TRANSFER WITH ORGANIC MEDIA.



To date Bertrams Heatec has supplied more than 3000 thermal fluid systems all over the world. They are used for a wide variety of chemical processes and perform an essential task in the higher temperature ranges.

QUALITY AND SERVICE FOR YEARS TO COME.

Bertrams Heatec systems are designed and built for trouble-free operation for many long years. We work in compliance with the international quality management standard ISO 9001:2000. This applies to all departments, from design work right through to after-sales service. Our equipment is certified by authorized inspection agencies recognized worldwide and bears their code symbol stamps for weld quality. We have developed our own fabrication and inspection methods for components subject to high temperatures and stresses. A constructive working relationship with our customers also contributes to the overall quality. Our customer-focused approach is exemplified by the long-term after-sales service given to our systems.



PROCESS HEAT TRANSFER WITH BERTRAMS HEATEC.

Many chemical reactions and process technologies are dependent on external heating or cooling. This is why thermal fluid systems by Bertrams Heatec are of such vital importance – whether in the manufacture of artificial fibres, synthetic resins (melamine) and caustic soda, in the production of aluminium and dyestuffs, or for other applications in the chemical, textile and food industries.

Temperature range of various media in degrees Celsius

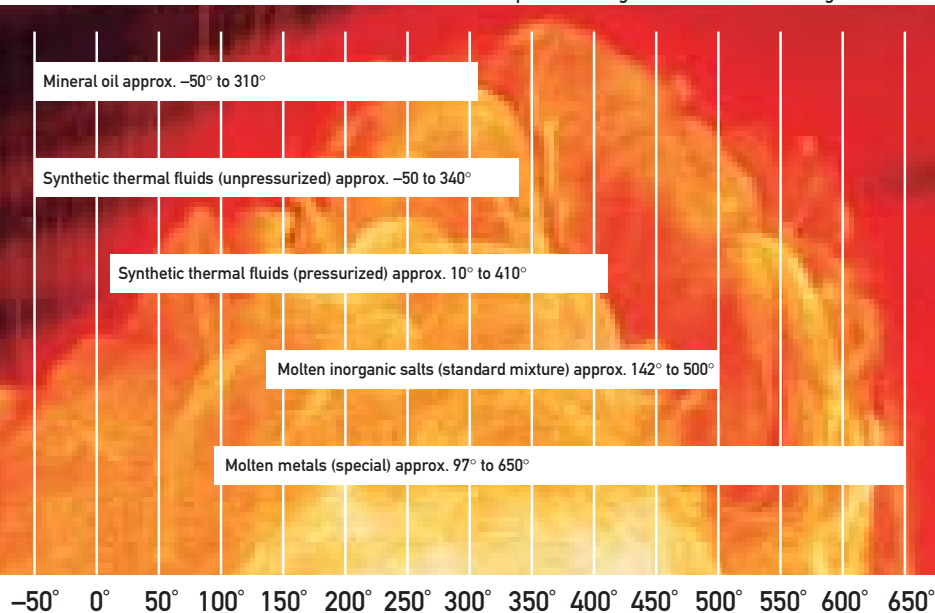

THERMAL FLUIDS: MINERAL OILS, SYNTHETIC PRODUCTS, MOLTEN SALTS, WATER-GLYCOL MIXTURES, GASES, MOLTEN METALS.

Various media are available as thermal fluids to suit the specified duty. Their temperatures are raised to the required levels in the thermal fluid heater. The temperature range selected is an important criterion when designing a thermal fluid system.

CUSTOMIZED INTEGRATED SYSTEMS – FOR THE RIGHT HEAT IN THE RIGHT PLACE.

Decades of experience have not only made us specialists in heat transfer by thermal fluids, but also the worldwide market leader in this field. We offer all plant components and engineering services from a single source – from project planning through fabrication to site installation. Every one of our systems is customized to meet your specifications; whenever possible we do not use standardized components. This approach creates ideal preconditions for maximum operational reliability and user-friendliness. It also ensures that each plant is designed for optimum cost-effectiveness and environmental soundness.

EXPERTISE IN HEAT TRANSFER WITH ORGANIC MEDIA.

OILS FOR TEMPERATURES FROM -50°C TO 410°C .

Mineral oils and synthetic oils are the most commonly used organic media for process heat transfer. Whether used in the liquid or vapour phases (flash system or secondary vaporizer), they form the ideal basis for supplying heat to a wide variety of production processes.

DESIGN FLEXIBILITY.

Bertrams Heatec can meet a broad range of specifications for process heat transfer.

Requirements range from 100 kW to about 45 MW per heater. Even larger capacities can be achieved by combining several units in a battery.

THERMAL FLUIDS IN THE LIQUID PHASE.

Thermal fluid systems can be designed with one or more secondary circuits with separate control loops to supply heat at different temperatures. Synthetic heat transfer oils can operate at temperatures up to 410°C .

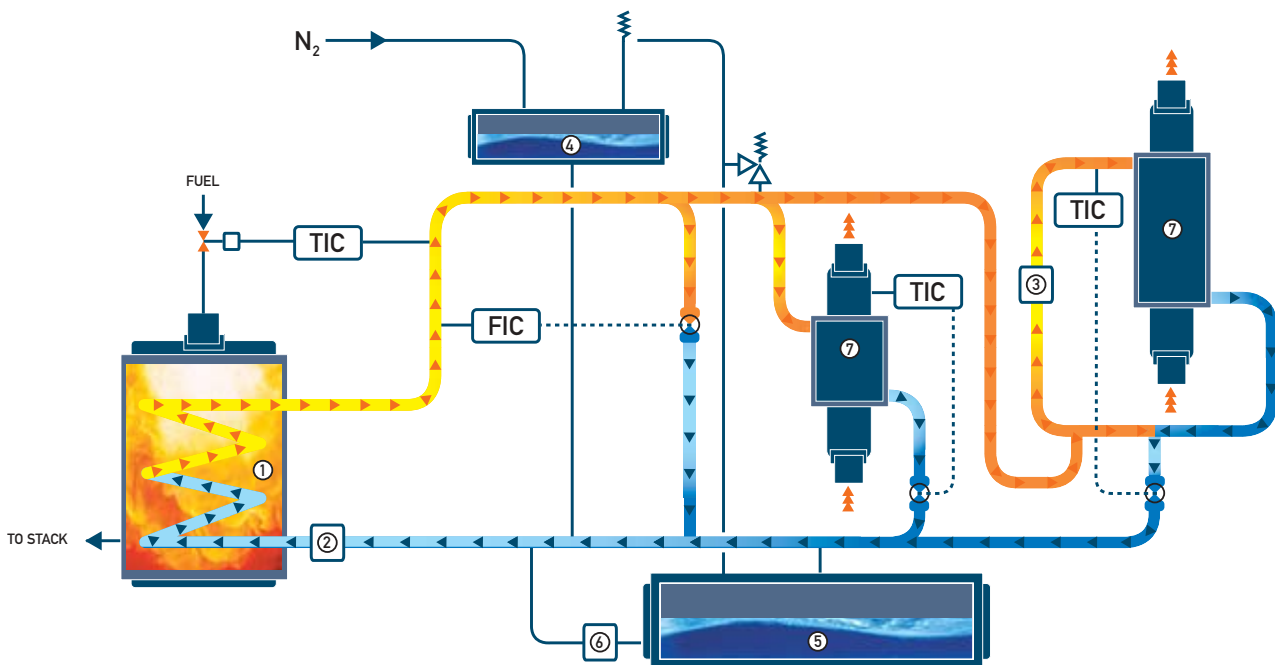

1. heater with burner
2. primary circulation pump
3. secondary circulation pump
4. expansion vessel
5. storage tank
6. fill pump
7. heat users



▲ Diphyl® flash system with a total output of 20 MW at 360°C supplying process heat to a DMT plant in Germany.

THERMAL FLUIDS IN THE VAPOUR PHASE.

Process heating using thermal fluids in the vapour phase (flash system or secondary vaporizer) enables a steady supply of heat to be distributed uniformly to several users.

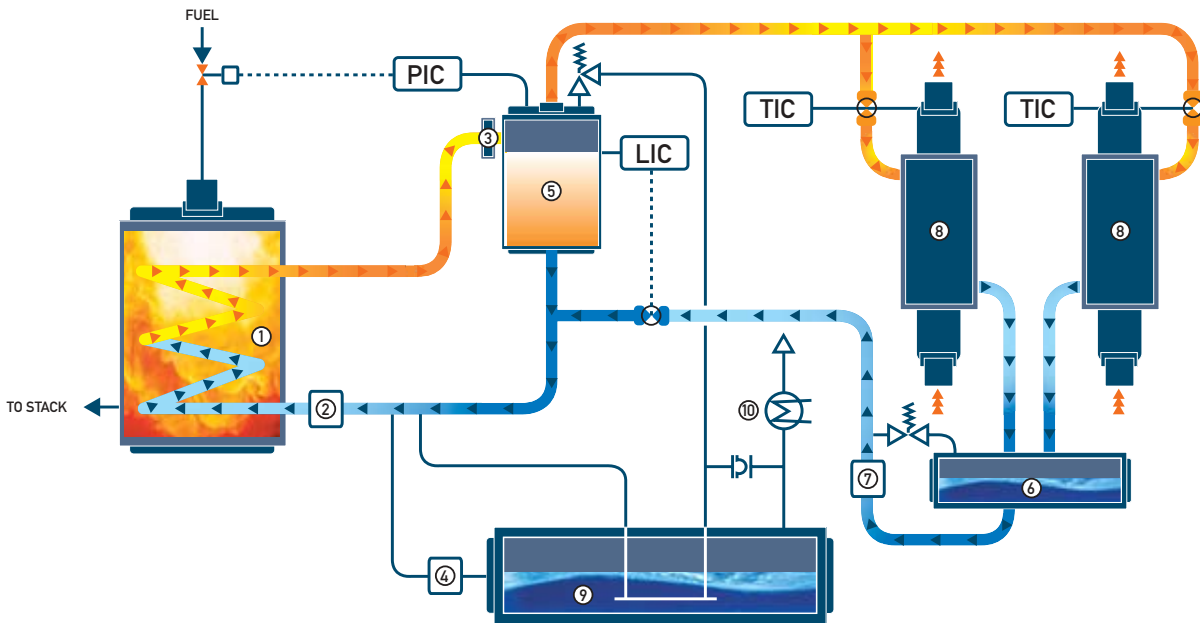

1. heater with burner
2. primary circulation pump
3. flash orifice
4. fill pump
5. flash tank
6. condensate tank
7. condensate pump
8. heat users
9. storage tank
10. condenser

THE TECHNICAL CORNER:

- Temperature ranges from -50° to 410°C
- Wide selection of capacities up to 45 MW per heater
- No radiant heat reflection as little refractory lining
- Optimum heat distribution through three-pass design
- Various firing orientations possible (downshot, vertically upwards, horizontally and inline)
- Heaters supplied completely assembled
- Suitable for various branches of industry
- Turnkey supplier responsibility
- Over 60 years experience in building thermal fluid systems

CUSTOMIZED SYSTEMS FOR EFFICIENT HEAT TRANSFER.

Bertrams Heatec designs, develops, manufactures and erects thermal fluid systems for heating a wide variety of processes. Every single project is executed to meet customer specifications exactly.

- Heat transfer with molten inorganic salts
- Heat transfer with organic media in liquid phase
- Heat transfer with organic media in vapour phase
- Heat transfer with water-glycol mixtures
- Fired process heaters for direct heat transfer
- Thermal fluid heaters and waste heat recovery systems for solid fuels
- Compact electric heaters

